



Description

Heavy duty joint covers for use in car parks, warehouses and ramps.

Installed after completion of the final floor finish. EPS System is optional.

Materials:

Anodized aluminium 6063/T6. Can also be supplied in mill finish aluminium.

EPS Joint Seal: 20m roll. Supplied with stainless steel anchors and screws.

Supply Lengths:

4m, custom lengths can be produced in order to minimize wastage.

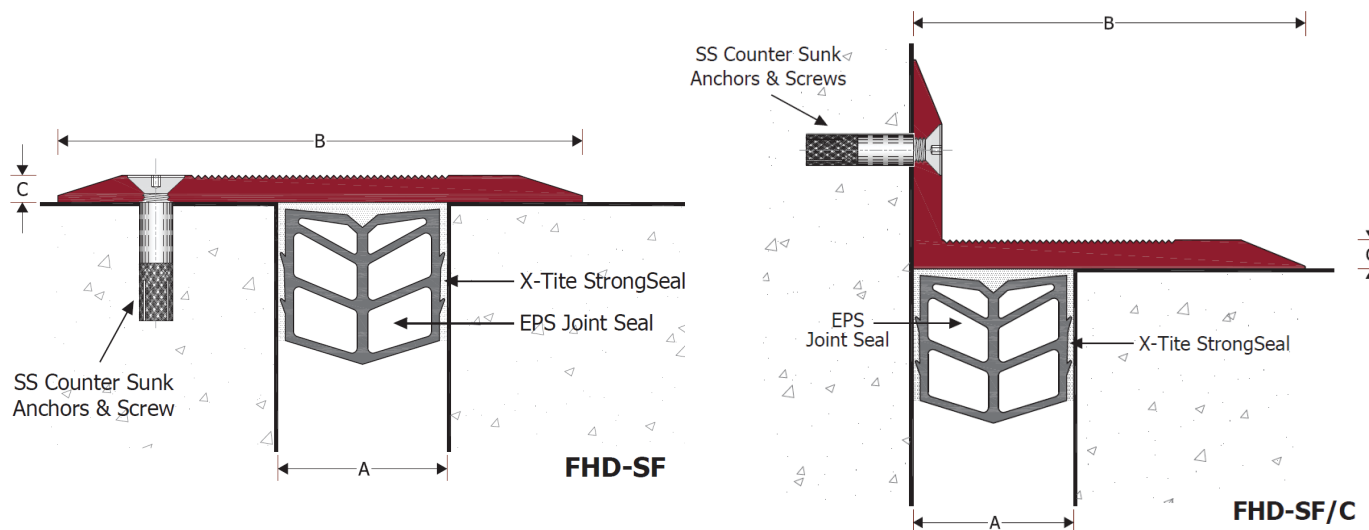

TYPE	A	B	C
FLAT PROFILE			
FHD-SF 110/40	5 to 40	110	6
FHD-SF 155/70	41 to 65	155	8
FHD-SF 185/100	66 to 100	185	9
FHD-SF 260/150	101 to 150	260	9.5
FHD-SF 325/200	151 to 200	325	12
CORNER PROFILE			
FHD-SF/C 110/40	5 to 40	64	6
FHD-SF/C 155/70	41 to 70	122	9
FHD-SF/C 185/100	71 to 100	122	9
FHD SF/C 260 /150	100 to 150	190	10
FHD SF/C 325 / 200	150 to 200	255	12

Dimension in mm

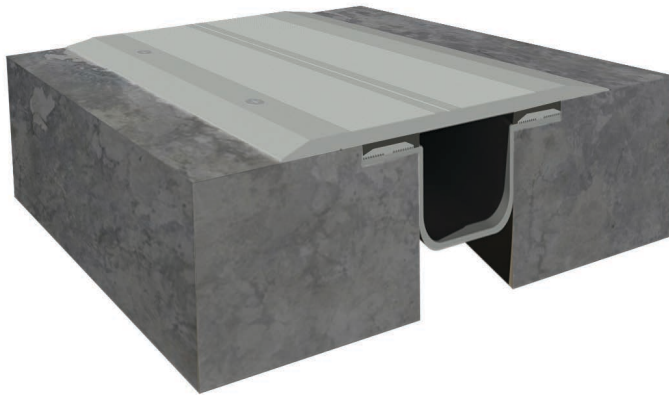

Description

Heavy duty joint covers for use in car parks, warehouses and ramps.

Installed after completion of the final floor finish. EPS System is optional.

Materials:

Anodized aluminium 6063/T6. Can also be supplied in mill finish aluminium.

EPS Joint Seal: 20m roll. Supplied with stainless steel anchors and screws.

Supply Lengths:

4m, custom lengths can be produced in order to minimize wastage.

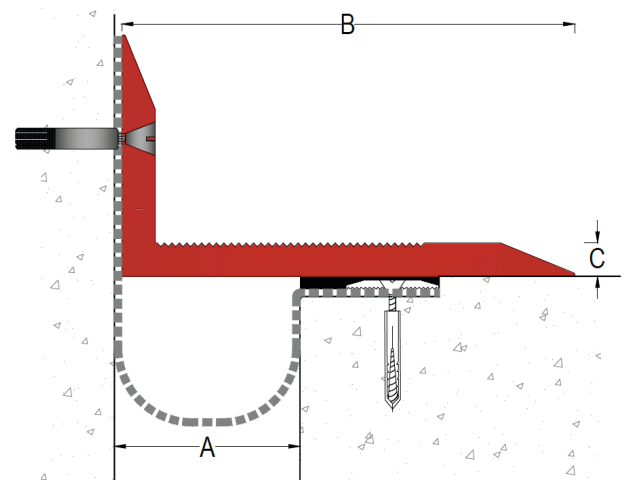
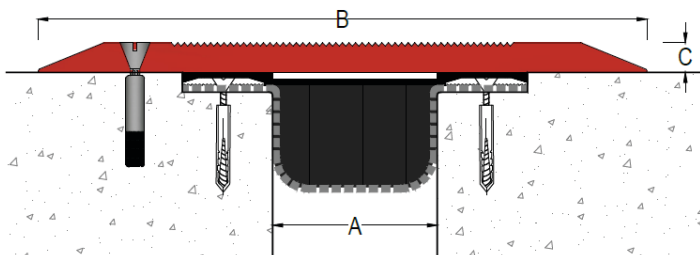

TYPE	A	B	C
FLAT PROFILE			
FHD-SF 110/40	5 to 40	110	6
FHD-SF 155/70	41 to 65	155	8
FHD-SF 185/100	66 to 100	185	9
FHD-SF 260/150	101 to 150	260	9.5
FHD-SF 325/200	151 to 200	325	12
CORNER PROFILE			
FHD-SF/C 110/40	5 to 40	64	6
FHD-SF/C 155/70	41 to 70	122	9
FHD-SF/C 185/100	71 to 100	122	9
FHD SF/C 260 /150	100 to 150	190	10
FHD SF/C 325 / 200	150 to 200	255	12

Dimension in mm